



Double-Wall Round – 2005 SMACNA Standards Positive Pressure to 10"

Standard Gauge Chart

Outer Pressure Shell (O.D.)

Concealed Duct

Diameter	Spiral Pipe	Spiral Profile	Longseam Pipe/Fittings	Standard Length
5" – 9"	26	Flat	24	10' – 0"
10" – 28"	26	Flat	24	10' – 0"
30" – 46"	24	Corrugated	22	10' – 0"
48" – 64"	22	Corrugated	20	10' – 0"
66" – 92"	20	Corrugated	18	10' – 0"

Exposed Duct

Diameter	Spiral Pipe	Spiral Profile	Longseam Pipe/Fittings	Standard Length
5" – 9"	26	Flat	24	8' – 0"
10" – 28"	26	Corrugated	24	8' – 0"
30" – 46"	24	Corrugated	22	8' – 0"
48" – 64"	22	Corrugated	20	8' – 0"
66" – 92"	20	Corrugated	18	8' – 0"

Inner Liner (I.D.)

Concealed Duct

Diameter	Spiral Pipe	Spiral Profile	Longseam Pipe/Fittings	Standard Length
3" – 9"	26	Flat	24	10' – 0"
10" – 28"	26	Flat	24	10' – 0"
30" – 46"	24	Corrugated	22	10' – 0"
48" – 64"	24	Corrugated	20	10' – 0"
66" – 90"	22	Corrugated	20	10' – 0"

Exposed Duct

Diameter	Spiral Pipe	Spiral Profile	Longseam Pipe/Fittings	Standard Length
3" – 9"	26	Flat	24	8' – 0"
10" – 28"	26	Corrugated	24	8' – 0"
30" – 46"	24	Corrugated	22	8' – 0"
48" – 64"	24	Corrugated	20	8' – 0"
66" – 90"	22	Corrugated	20	8' – 0"

Standard fittings to be spot welded and sealed. Continuously welded seam fittings are available if specified. All PCD and SPOT AgION fittings are riveted and sealed.

Inner liner can be solid or perforated. Perforated material to have 3/32" holes and 3/16" staggered centers for a 23% open area.



One inch insulation layer to meet requirements set forth in NFPA pamphlet #90A as to flame spread and smoke developed. K-value at 75 degree M.T. = 0.26 BTU.

Available Materials

G90 Galvanized
Phosphatized (Galvanneal)
304 Stainless Steel
316 Stainless Steel
PCD (Polyvinyl Coated Galvanized)
3003 Aluminum
SPOT AgION™ (Antimicrobial)

Connectors

Standard Slip-fit/Couplings
SPOT Flange™
Angle Ring

Spiral Profiles

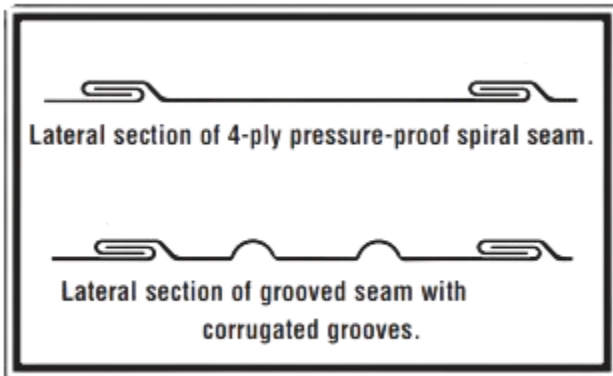

Spiral Pipe of Texas products are manufactured in accordance with the latest SMACNA, ASHRAE, and SPIDA standards. In an on-going effort to improve our products, Spiral Pipe of Texas reserves the right to revise the design and/or specifications of its products as technology advances or applicable standards change.

Double-Wall Round Spiral Pipe and Fitting Standards

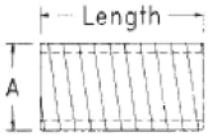
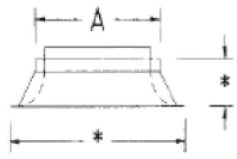
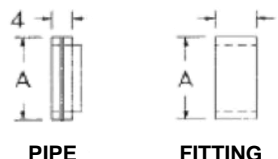
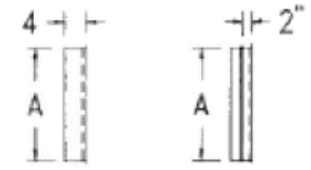
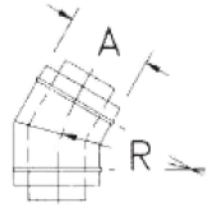
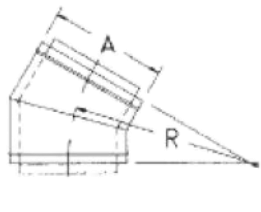
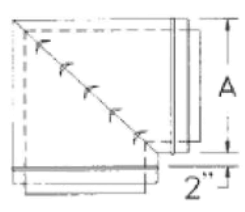
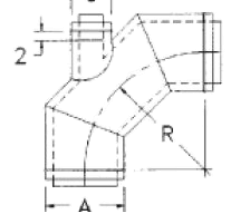
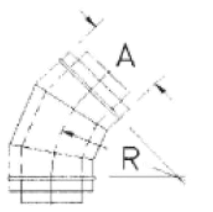
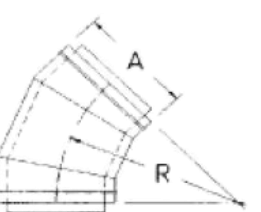
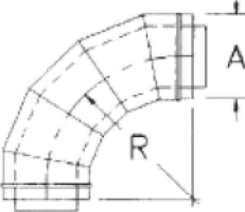
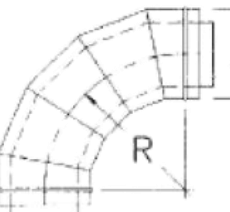
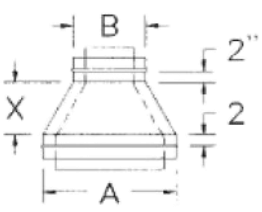
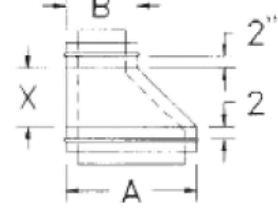
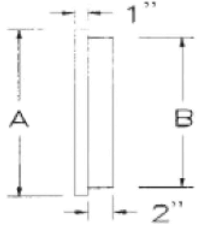
Dimensions			
A = Inlet B = Outlet C = Branch D = Branch H = 3" if C = 3" to 8" 6" if C = 9" to 16" 9" if C = 17" to 24" 12" if C = 25" & Up		K = 5 1/4" L = Offset Length O = Offsetting Amount R = 1.5 x A S = 2 T = A/4 + 2 U = A x 2 + 2 **Dimension of Liner = O.D. - (2 x Insulations Thickness) ***End of Liner Extends 2" Past Ends of Fittings	
$V = (A/2 \times 1.414) + ((C + 2)/2) + 6$ $W = (C + 2) \times 1.414 + 4$ X = 12" if A - B = 18" or Less 24" if A - B = 19" or Greater $Y = (1.414 \times C) + 4$ $Z = C + H + 4$ * = Consult Factory			
SP	B1	PP	FF
			
Spiral Pipe	Bellmouth	Couplings	Caps & Plug
E1 Thru E36		EV90	
			
A = 3" Thru 24"	A = Greater than 24"	A = 3" Thru 60"	A = 3" Thru 60"
2 Gore Elbows		Mitered Elbow	
E37 Thru E71		E72 Thru E90	
			
A = 3" Thru 24"	A = Greater than 24"	A = 3" Thru 24"	A = Greater than 24"
3 Gore Elbows		5 Core Elbows	
R1	ER1	SD	
			
Reducers		Stepdown	

Double-Wall Round Spiral Pipe and Fitting Standards

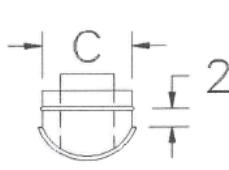
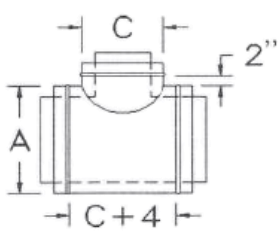
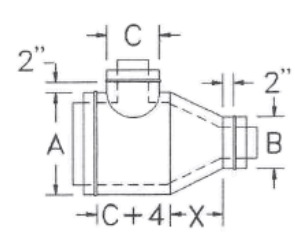
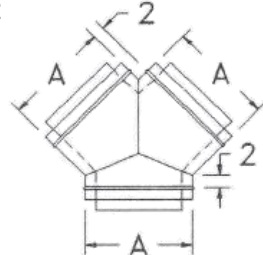
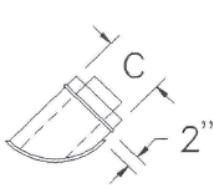
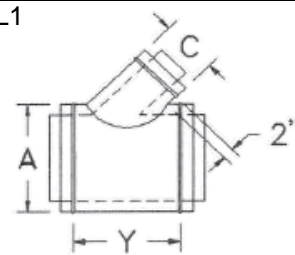
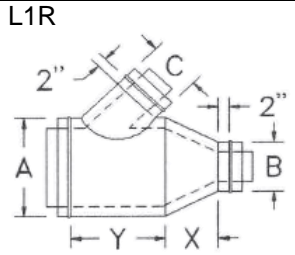
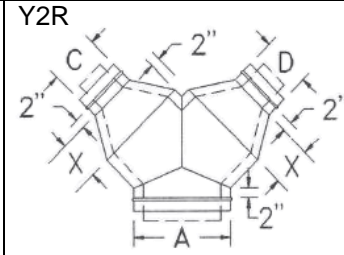
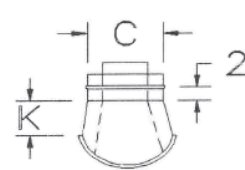
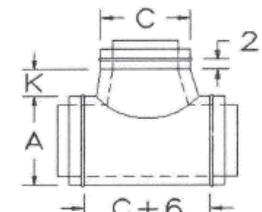
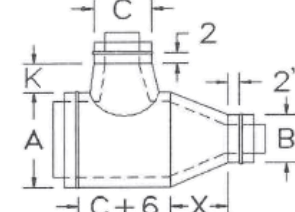
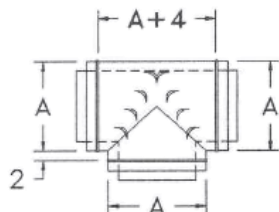
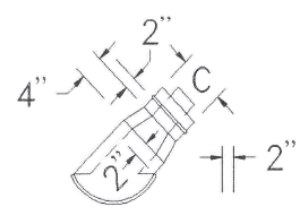
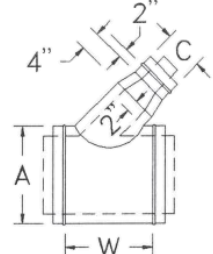
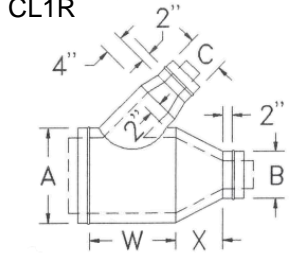
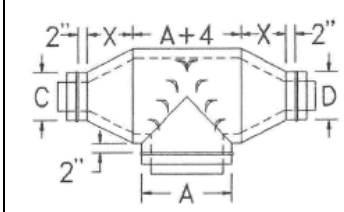
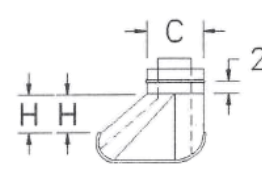
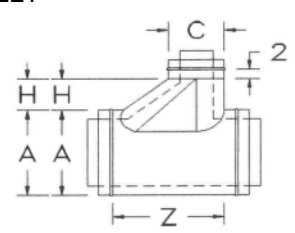
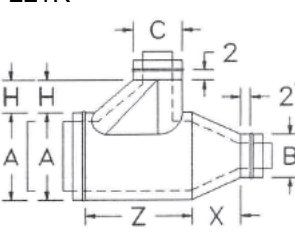
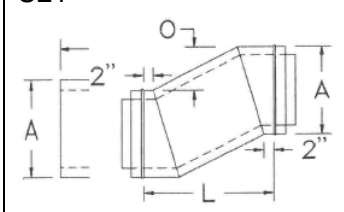
LT 	T1 	T1R 	Y2 
Straight 90 Degree Tees			"Y" Fitting
LL 	L1 	L1R 	Y2R 
45 Degree Lateral Tees			Reducing "Y" Fitting
LCT 	CT1 	CT1R 	BT 
Conical 90 Degree Tees			Bullhead Tee
LCL 	CL1 	CL1R 	BTR 
Conical 45 Degree Lateral Tees			Reducing Bullhead
LLL 	LL1 	LL1R 	SET 
Low Loss 90 Degree Tees			Offset