



Double-Wall Round – 1995 SMACNA Standards Positive Pressure to 10"

Standard Gauge Chart

Outer Diameter Shell (O.D.)

Diameter	Spiral Pipe	Longseam Pipe	Fittings
5" – 10"	26	26	26
11" – 14"	26	24	24
15" – 26"	24	22	22
28" – 36"	22	20	20
38" – 50"	20	20	20
52" – 60"	18	18	18
62" – 84"	18	16	16

Inner Liner (I.D.)

Diameter	Spiral Pipe	Longseam Pipe	Fittings
3" – 26"	26	26	26
37" – 50"	26	24	24
51" – 60"	24	22	22
61" – 84"	22	20	20

One inch insulation layer to meet requirements set forth in NFPA pamphlet #90A (catalogue NFPA #255) as to flame spread and smoke developed ratings. K-value at 75 degree M.T. = 0.26 BTU.

Available Materials

G90 Galvanized
 Phosphatized (Galvanneal)
 304 Stainless Steel
 316 Stainless Steel
 PCD (Polyvinyl Coated Galvanized)
 3003 Aluminum
 SPOT AgION™ (Antimicrobial)

Spiral Pipe of Texas products are manufactured in accordance with the latest SMACNA, ASHRAE, and SPIDA standards. In an on-going effort to improve our products, Spiral Pipe of Texas reserves the right to revise the design and/or specifications of its products as technology advances or applicable standards change.

Double-Wall Round Spiral Pipe and Fitting Standards

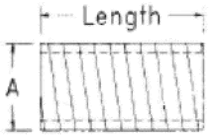
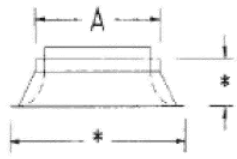
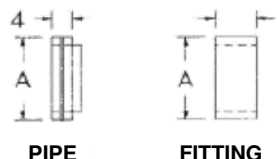
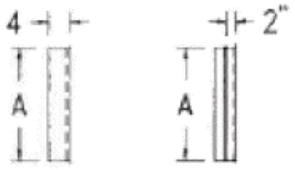
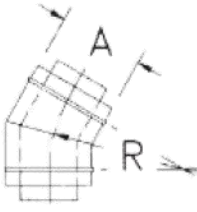
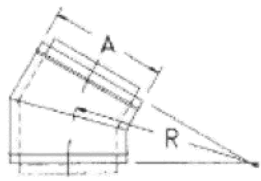
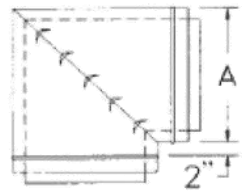
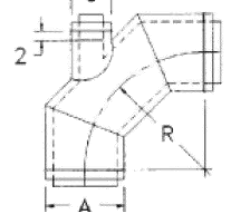
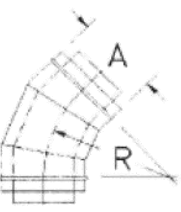
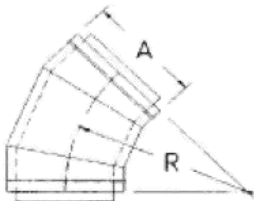
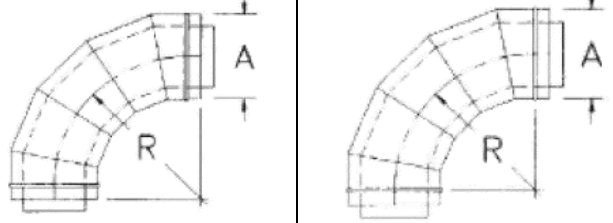
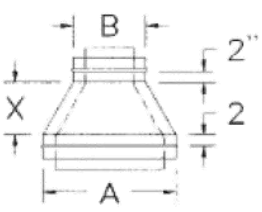
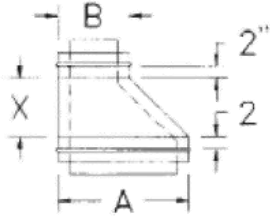
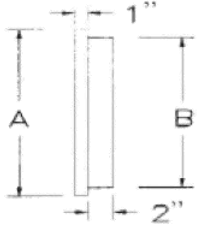
Dimensions			
A = Inlet B = Outlet C = Branch D = Branch H = 3" if C = 3" to 8" 6" if C = 9" to 16" 9" if C = 17" to 24" 12" if C = 25" & Up	K = 5 1/4" L = Offset Length O = Offsetting Amount R = 1.5 x A S = 2 T = A/4 + 2 U = A x 2 + 2 **Dimension of Liner = O.D. - (2 x Insulations Thickness) ***End of Liner Extends 2" Past Ends of Fittings	$V = (A/2 \times 1.414) + ((C + 2)/2) + 6$ $W = (C + 2) \times 1.414 + 4$ X = 12" if A - B = 18" or Less 24" if A - B = 19" or Greater $Y = (1.414 \times C) + 4$ $Z = C + H + 4$ * = Consult Factory	
SP	B1	PP	FF
			
Spiral Pipe	Bellmouth	Couplings	Caps & Plug
E1 Thru E36	E1 Thru E36	EV90	ET90
			
A = 3" Thru 24"	A = Greater than 24"	A = 3" Thru 60"	A = 3" Thru 60"
2 Gore Elbows		Mitered Elbow	Elbow w/ Tap
E37 Thru E71	E37 Thru E71	E72 Thru E90	
			
A = 3" Thru 24"	A = Greater than 24"	A = 3" Thru 24"	
3 Gore Elbows		5 Core Elbows	
R1	ER1	SD	
			
Reducers		Stepdown	

Double-Wall Round Spiral Pipe and Fitting Standards

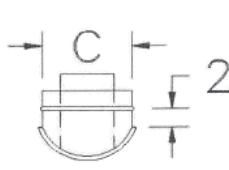
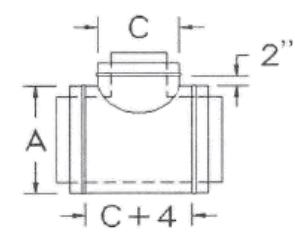
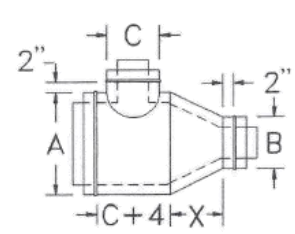
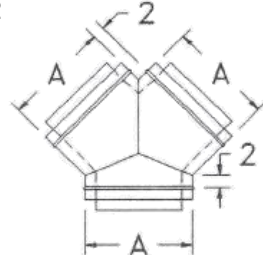
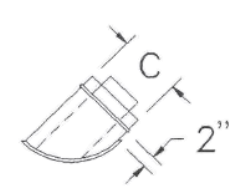
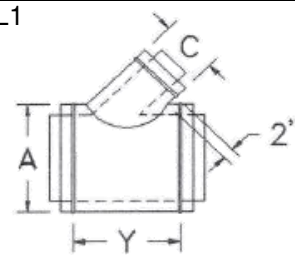
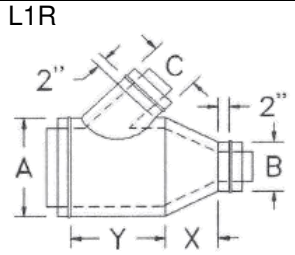
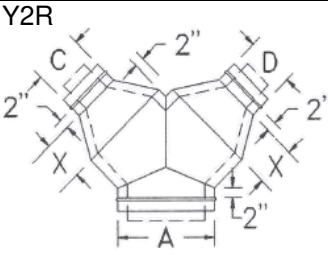
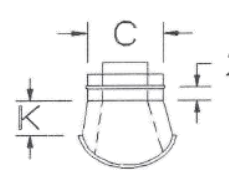
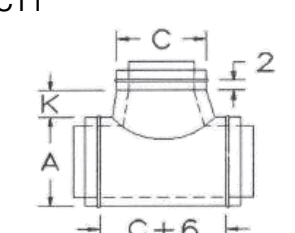
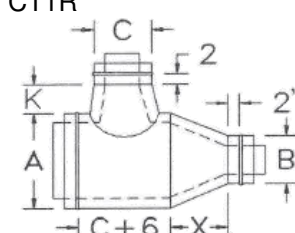
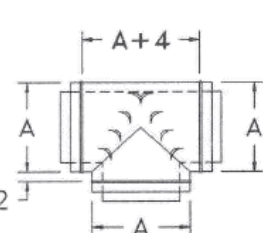
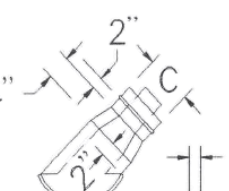
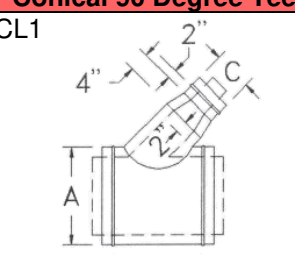
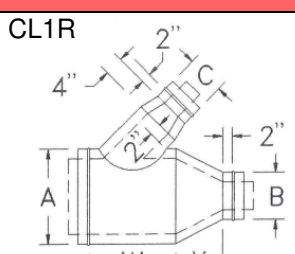
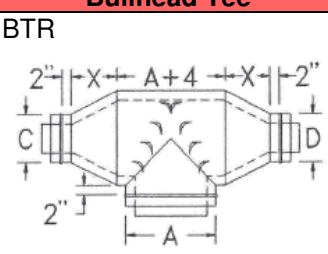
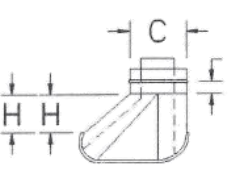
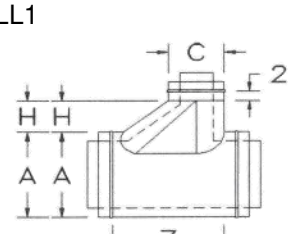
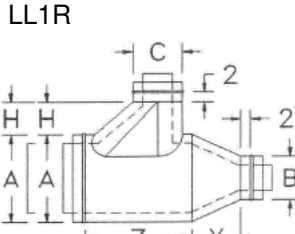
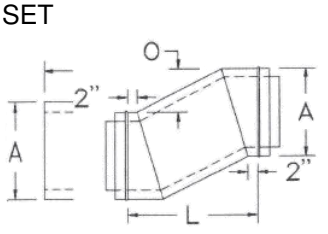
LT 	T1 	T1R 	Y2 
Straight 90 Degree Tees			"Y" Fitting
LL 	L1 	L1R 	Y2R 
45 Degree Lateral Tees			Reducing "Y" Fitting
LCT 	CT1 	CT1R 	BT 
Conical 90 Degree Tees			Bullhead Tee
LCL 	CL1 	CL1R 	BTR 
Conical 45 Degree Lateral Tees			Reducing Bullhead
LLL 	LL1 	LL1R 	SET 
Low Loss 90 Degree Tees			Offset