

PhenoliDuct™

from Spiral Pipe of Texas
Your *Round* Solution for Rooftop HVAC Duct Systems

Patent Pending

Finally, there is a solution to your rooftop duct system needs that is the right shape, the right material and the right price. We have combined our 40+ years of quality metal duct fabrication with a willingness to innovate and explore new technologies. The result is PhenoliDuct™. We combine the proven technology of our double-wall duct manufacturing with the properties of Kingspan KoolDuct® to give you the perfect rooftop ducting solution.



It's Round! Rooftop duct should be round, when possible. The round shape sheds rainwater, prevents excessive snow, and ice loads. However, the most significant reason for most of the country is wind. A round duct experiences about 40% of the wind force a comparable rectangular duct would see. Hanger and support spacings are greater for round ducts. This is truly a round duct, not an 8 or 12-sided adaptation from rectangular duct. Our standard construction uses our spiral duct as the outer shell and a round metal longitudinal-seam duct for the inner shell. The performance will be the same for SPOT's other round duct products, as well.

It's Closed-Cell! Owners and designers want a product that will not wick or retain moisture. The Kingspan KoolDuct® insulation is closed cell. In addition, our fabrication process retains the foil scrim barrier on the outer perimeter of the insulation, eliminating water vapor transmission.

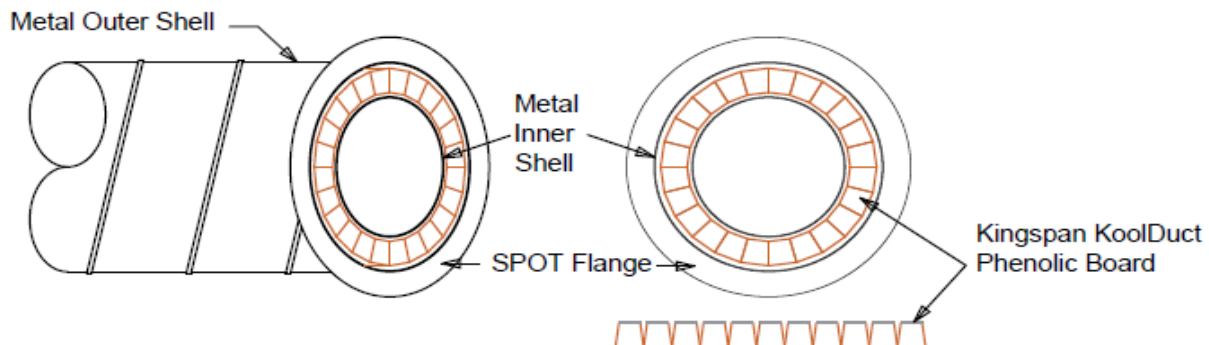



Exceptional Thermal Performance! Our standard product uses the KoolDuct® 45mm board. This product has an R-value of 12.0. It is machined to fill a 2" annular space in our double-wall construction, and our process eliminates all potential thermal gaps. This is 50% more thermal performance in a 2" insulation product than you would get with fiberglass or elastomeric insulations.

Exceptional Surface Burning Characteristics!

The KoolDuct® board used as insulation has flame spread and smoke developed indices of 10 when tested per ASTM E84. This greatly out-performs other insulations that struggle – and often fail – to reach the minimum 25/50 indices required by most codes. SPOT can provide desirable characteristics such as fully-welded fittings without worrying about setting the insulation on fire. Our customers can also perform field-modifications to the duct without creating a fire hazard.



It's Durable! Sheet metal ducts, and particularly spiral ducts, are proven to be durable in outdoor applications. Other rooftop products have been introduced, including some made with phenolic board. Most are simply one or two layers of insulating board with an external lagging applied. These have neither the strength nor durability of double-wall metal construction.

It Is Easy to Install! If you have installed double-wall spiral duct, you already know how to install this product. Actually, it's even easier to install than our fiberglass insulated products. The rigidity of the phenolic board and the close tolerances of our annular construction eliminate the need for an inner coupling. Most installations will only need external bolted companion angle rings or our economical SPOT-Flanges.



Lots of material and fabrication options! We can provide the inner and outer metal shells as galvanized steel (standard), galvanized steel, epoxy coated steel, PCD (Polyvinyl Coated Galvanized), black iron, 3003 aluminum, 304 stainless steel or 316 stainless steel. We can provide the metal shells as spiral duct or longitudinal seam welded duct. We offer spiral lock-seam construction, tack-welded and sealed construction, MIG, and TIG welding. We can offer the product as flat oval or rectangular construction, as well. We can factory-assemble manifolds of duct and fittings to minimize field work. Essentially, we can offer just about all products from our SPOT catalog in PhenoliDuct™ construction.



Phenomenal Price!

This is the good part. We are competitive with other closed-cell insulated duct products – elastomeric, foam filled, and even other phenolic products. We aren't spending time and money trying to overcome properties that don't lend themselves to the application. We simply developed a way to use the best rooftop metal duct fabrication, SPOT's double-wall round spiral duct, with the best rooftop insulation material Kingspan's KoolDuct® phenolic system. The result is 50% more R-value at 20-50% less cost.



Insulation Characteristics	SPOT PhenoliDuct™	Fiberglass	Fiberglass	Johns Manville Permacote® Linacoustic®	AP/Armaflex®	AP/Armaflex®	AP/Armaflex FS®	K-Flex® Duct Liner Gray	K-Flex® Duct Liner Gray	Ductmate PolyArmor™	Ductmate PolyArmor™	PremiPour™ 202M	Baytherm® 9912	PTM Dual-Tech®	ThermaDuct™ R-8.1	ThermaDuct™ R-12	Johns Manville Spiracoustic Plus®	AP/Spiralflex®
Insulation Thickness	1-3/4"	1"	2"	2"	1"	2"	2"	1"	2"	1"	2"	1"	1"	1-3/16" X 2	1-3/16"	1-3/4"	2"	1"
R-Value	12.0	4.2	8.0	8.0	4.2	8.0	8.0	4.2	8.0	4.2	8.0	6.7	6.6	16.0	8.1	12.0	8.4	4.2
Fiber-Free	Yes	No	No	No	Yes	Yes	Yes	Yes	Yes	No	No	Yes	Yes	Yes	Yes	Yes	No	Yes
Closed Cell (≥90%)	Yes	No	No	No	Yes	Yes	Yes	Yes	Yes	No	No	No	Yes	Yes	Yes	Yes	No	No
25/50	Yes	Yes	Yes	Yes	Yes	No	Yes	Yes	Yes	Yes	Yes	No	No	Yes	Yes	Yes	Yes	No
Density (PCF)	3.5	1	1	~3.8	~5.0	~5.0	~5.0	3 - 4	3 - 4	1.6	1.4	2.0	2.2	3.5	3.5	3.5	~3.8	~5.0
Water Absorption, % by volume	1.15%	< 3%	< 3%	< 3%	0.20%	0.20%	0.20%	<0.2%	<0.2%	0.24%	0.24%	0.05	3.56%	1.15%	1.15%	1.15%	<3%	0.20%
Round	Yes	Yes	Yes	Yes	No	No	No	No	No	Yes	Yes	Yes	Yes	No	No	No	Yes	Yes
Flat Oval	Yes	Yes	Yes	Yes	No	No	No	No	No	Yes	Yes	No	No	No	No	No	No	No
Rectangular	Yes	Yes	Yes	Yes	Yes	Yes	Yes	Yes	Yes	Yes	Yes	No	No	Yes	Yes	Yes	Yes	No
Smooth Metal Inner Airway	Yes	Yes	Yes	Yes	Yes	Yes	Yes	Yes	Yes	Yes	Yes	Yes	Yes	Yes	Yes	Yes	No	No
Durable External Shell	Yes	Yes	Yes	Yes	Yes	Yes	Yes	Yes	Yes	Yes	Yes	Yes	Yes	Yes	Yes	Yes	Yes	Yes
Can you weld metal on it without it smoldering, smoking or catching on fire?	Yes	Yes	Yes	Yes	No	No	No	No	No	No	No	No	No	No	No	No	Yes	No
Maximum Pressure WG (positive)	10"	10"	10"	10"	10"	10"	10"	10"	10"	10" WG	10"	10"	10"	6" WG	6" WG	6" WG	6" WG	10"
Maximum Pressure WG (negative)	-6"	-6"	-6"	-6"	-6"	-6"	-6"	-6"	-6"	-6" WG	-6"	-6"	-6"	-6" WG	-6" WG	-6" WG	-6" WG	-6"
Cost	\$\$\$	\$	\$\$	\$\$	\$\$\$\$	\$\$\$\$\$	\$\$\$\$\$	\$\$\$\$\$	\$\$\$\$\$	\$\$	\$\$\$	\$\$\$\$	\$\$\$\$\$	\$\$\$\$\$	\$\$\$\$	\$\$\$\$\$	\$\$	\$\$\$\$\$
Install Labor	\$	\$	\$	\$	\$	\$	\$	\$	\$	\$	\$	\$	\$	\$\$	\$\$	\$\$	\$	\$\$
	Double-Wall Sheet Metal Construction											Double-Wall Foam Filled		Built-Up Insulation Board with External Lagging			Lined Duct (no inner metal shell)	

Contact your SPOT Representative for more information.

Corporate Office
P.O. Box 161547
Fort Worth, TX 76161-1547
Revised August 2022

Manufacturing Facility
600 N. Hays St.
Fort Worth, TX 76102

Phone: 817.877.3543
Fax: 817.877.3545
spotusa.com